

Oil Pumps

Mini Fire-Ball® 225, Fire-Ball 300 and Fire-Ball 425

Features and Benefits

- Non-corrosive air motor design for long life (metal parts made of stainless steel, aluminum and chrome)
- No metal-to-metal contact means longer pump life and ensures pump will withstand harsh environments
- Double-acting pump provides reliable fluid flow
- Few moving parts translates into low maintenance and low cost of ownership
- Open exhaust port provides continuous operation without icing

Typical Applications

- Medium to low volume and pressure lubricant transfer
- Automotive dealerships
- Heavy-duty dealerships
- Fast lube centers and service shops
- Fleet service facilities
- In-plant
- Lube trucks
- Mining

Typical Fluids Handled

- Petroleum-and synthetic-based oils

Mini Fire-Ball 225, 3:1 Performance Chart

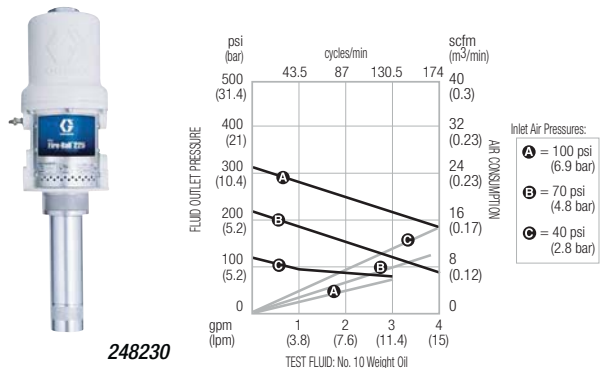

Fire-Ball 300, 5:1 Performance Chart

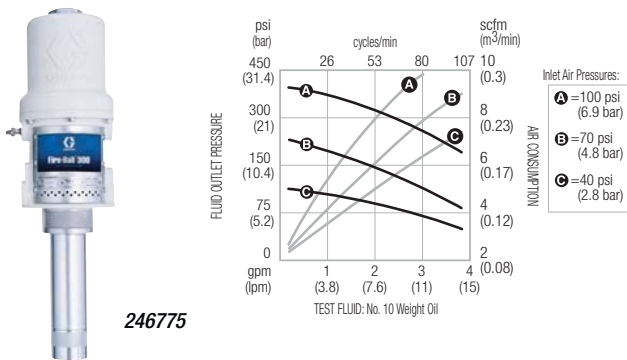

Fire-Ball 425, 3:1 Performance Chart

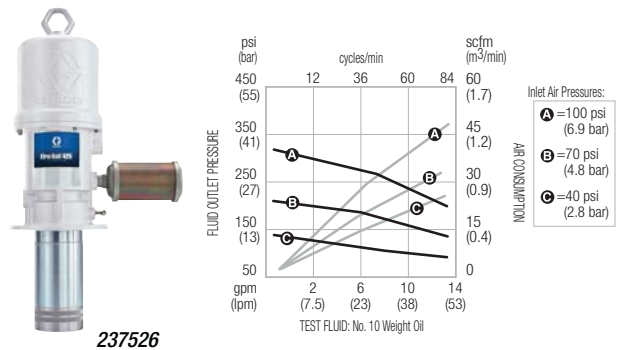

Fire-Ball 425, 6:1 Performance Chart

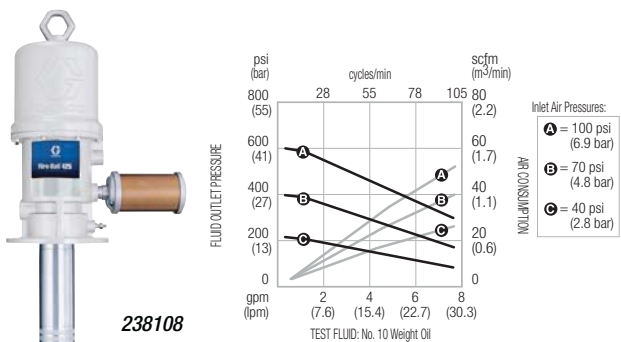

Fire-Ball 425, 10:1 Performance Chart

